

**THE CORPORATION OF THE
TOWNSHIP OF GILLIES**

REQUEST FOR QUOTATION

Pee Dee Park Gazebo Construction

Project #2010-01ISF

March 10, 2010

TABLE OF CONTENTS

1.0 INTRODUCTION

2.0 PROPOSAL REQUIREMENTS

3.0 GENERAL REQUIREMENTS

4.0 SUBMISSION REQUIREMENTS

5.0 PROPOSAL EVALUATION

6.0 DRAWINGS

1.0 INTRODUCTION

The Township of Gillies is located 35 km southwest of Thunder Bay, Ontario. Pee Dee Park is located in the village of Hymers along Highway 595, at the intersection of Main Street and Pee Dee Road.

The Corporation of the Township of Gillies invites bidders to submit a quotation for the supply of materials and construction of a 10' X 10' gazebo structure at Pee Dee Park.

This request is intended to assist bidders in gaining an understanding of the Township of Gillies' requirements, however, it remains the responsibility of each bidder to verify all the information required.

2.0 PROPOSAL REQUIREMENTS

- 2.1 All materials for the construction of the gazebo are to be provided by the contractor, including gravel, big foot bases, sono tubes, plastic covering for sono tubes, treated posts, concrete, pressure treated beams, roof strapping, hip roof material, dark green coloured metal roofing with matching snow stops, white fascia, white metal for capping of beams and posts, miscellaneous hardware, geotextile (ground cloth), 5/8" gravel and any other material that may be required to complete the project.
- 2.2 Remove top soil from the construction area and retain on site for future use.
- 2.2 Ground within gazebo area to be covered with a ground cloth (geotextile) and finished with 5/8" 'A' gravel.
- 2.3 All work to be done in accordance to the attached drawings (see Section 6).
- 2.4 Provide a detailed schedule to carry out the work required. Once work has commenced, the project must be finalized within 14 days, with all work to be completed by May 21, 2010. A penalty of \$100 per day for each day over the 14 day allowable construction period shall be deducted from the final payment to the contractor. Consideration will be given to extreme weather conditions that may affect construction during that period.

- 2.5 Worksite must be controlled and kept free of debris in a manner that allows for the safe continual operation of the Park.
- 2.6 No mandatory site visit is required, but those bidders unfamiliar with the site are encouraged to visit the site prior to submission of a Proposal in order to determine the scope of the work to be completed.

3.0 GENERAL REQUIREMENTS

- 3.1 State applicable taxes separately.
- 3.2 Proof of liability insurance, minimum liability must be \$2,000,000.000 CDN and Workplace Safety Insurance Board clearance certificate.
- 3.3 Successful respondent must comply with all Township of Gillies health and safety policies.

4.0 RFQ SUBMISSION REQUIREMENTS

4.1 Respondent to Ensure its Understanding of Project

It is the Respondent's responsibility to ensure that it has all the necessary information concerning the intent and requirements of the RFQ and project and seek clarification (as set out in Section 4.2) of any matter it considers to be unclear. The Township of Gillies is not responsible for any misunderstanding of the RFQ on the part of the Respondent.

4.2 Enquires

No Respondent may claim any advantage from any error, inconsistency or omission in this RFQ. Any Respondent who has questions as to the meaning of any part of this RFQ or the project or who believes the RFQ contains any error, inconsistency or omission must make an enquiry in writing requesting clarification, interpretation or explanation. Written enquires are to be submitted to the Township of Gillies by email or fax only to:

Email: gillies@tbaytel.net

Fax: (807) 473-0767

The Township of Gillies reserves the right to distribute any or all questions and answers to other Respondents.

Respondents are requested NOT to make verbal inquiries of Township of Gillies staff or council members and are reminded that as set forth in section 4.3, oral information provided to any Respondent will not be binding on the Township of Gillies.

4.3 Oral Information

Information given orally by the Township of Gillies or by means of wire or telephone will not be binding nor will it be construed as to change the requirements of the RFP in any way.

4.4 Information

All requirements, designs, documentation, plans and information obtained by the Respondent in connection with this RFQ are the property of the Township of Gillies and must be treated as confidential and not used for any other purpose than replying to the RFQ and the fulfillment of any subsequent contract. Upon request of the Township of Gillies, all such designs, documents, plans and information shall be returned to the Township of Gillies.

4.5 Contact Person

Each Respondent is requested to designate, one individual to whom any additional information deemed relevant to the RFQ might be communicated.

4.6 One Proposal

Respondents may only submit one (1) Proposal.

4.7 Last Date for Submission

Respondents are requested to submit one copy of the Proposal, in a sealed package clearly marked RFQ #2010-01ISF to:

Township of Gillies
R.R. #1, 1092 Hwy 595
Kakabeka Falls ON P0T 1W0

Submissions can be dropped off at the above address Monday to Thursday between 9 AM and 4:30 PM, or mailed, but all submissions must be received at the above address no later than April 7, 2010 at 3 PM local time (EST).

4.8 Late or Unsigned Proposals

Late Proposals will not be considered and will be returned unopened. An authorized signing officer of the Respondent must sign all Proposals. **Unsigned Proposals shall be disqualified.**

4.9 Incomplete Proposals

The Township of Gillies reserves the right to reject any Proposal whether or not completed properly and whether or not it contains all required information. Without prejudice to this right, the Township of Gillies may request clarification where any Respondent's intent is unclear and may waive or request amendment where in the opinion of the Township of Gillies there is a MINOR irregularity or omission in the information that is to be submitted in a required document.

4.10 Irrevocable Proposal

The Proposal submitted is irrevocable the Respondent and will remain in effect and open for acceptance by the Township of Gillies for a period of one ninety (90) days after the last day for the submission of Proposals.

4.11 Changes to Proposals

No alteration will be accepted after the specified closing time for submitting Proposals. However, the Respondent may alter or withdraw its Proposal at any time before the closing time.

4.12 Confidential Proposals

The Township of Gillies will consider all Proposals as confidential, subject to the provisions of the disclosure requirements of the *Municipal Freedom of Information and Protection of Privacy Act*, R.S.O. 1990, c. M.56, as amended from time to time. The Township of Gillies will, however, have the right to make copies of all Proposals received for its internal review process.

4.13 No Liability for Expenses

In the event that any Proposal is not accepted, the Township of Gillies will not be liable for any costs or damages incurred by any Respondent including, without limitation, any expenses incurred in the preparation and submission of the Proposal.

4.14 Verification

The Township of Gillies reserves the right to verify any information provided in any Proposal by whatever means it deems appropriate including contacting references other than those offered, and to reject any such information if, in the judgment of the Township of Gillies, such information is not verifiable.

4.15 Misleading Information

It must be clearly understood that if there is any evidence of misleading or false information having been given, the Township of Gillies may, in its sole discretion, reject the Proposal.

4.16 Changes to RFQ

Any changes or revisions to the RFQ will be issued as a formal addendum to all Respondents.

4.17 Lowest Price

The Proposal with the lowest price for the work stated will not be necessarily selected. While price is an important element in the selection process, it is to be clearly understood that there are many other factors that the Township of Gillies will consider in examining Proposals. (See Evaluation Criteria, Section 5.1)

4.18 Conflict of Interest

The Respondent is required to disclose any real, apparent or potential conflict of interest that comes to its attention in preparing the Proposal, during the evaluation or during the term of any subsequent agreement. The Respondent shall accept any determination by the Township of Gillies, in respect of such conflict, including any requirements to withdraw from the bidding agreement.

4.19 Award of Project

All proposals received by the last date of submission stated in section 4.7 will be reviewed by council at the council meeting of April 12, 2010.

The Township of Gillies will have the right to select from among the Proposals received, one Respondent to whom the project will be awarded. The Township of Gillies reserves the right in its sole discretion and for any reason whatsoever:

- to accept or to reject any or all Proposal in whole or in part;
- not to proceed with all or any part of the project.

The acceptance of a Proposal and the award of this project or any thereof will be made in writing and only in writing. The successful Respondent may be required to enter into and duly execute a written contract with the Township of Gillies. In the event that a successful Respondent fails or refuses to enter into and duly execute a written contract acceptable to the Township of Gillies within a reasonable time, the Township of Gillies reserves the right, at its sole discretion, to award the contract to another Respondent, not to accept any Proposal, or to call for a new Proposal, and the defaulting Respondent shall be liable for all losses, damages, costs and expenses (including consequential losses and damages, and legal fees on a solicitor and client basis) suffered or incurred by the Township of Gillies as a direct or indirect result thereof, including but not limited to any increase in the price of performance over the price submitted by the defaulting Respondent in its Proposal.

5.0 PROPOSAL EVALUATION

5.1 Evaluation Criteria

The evaluation of the Proposal will be based on the following criteria, which are not listed in any particular order, together with any other criteria relevant to the matters addressed in this RFP:

1. The quality of the Respondent's Proposal.
2. An assessment of the extent to which the Proposal satisfies the conditions of this RFP, including the ability to meet these requirements within the proposed time frame.

3. The reputation and stability of the Respondent.
4. An assessment of the capability of the Respondent to provide the level and quality of services required within the schedule proposed.
5. Price (see Section 4.17 of RFQ).

6.0 DRAWINGS

Included are three drawings; (1) Site Plan Detail; (2) Top View; and (3) Side View.

G.1 Site Plan Detail

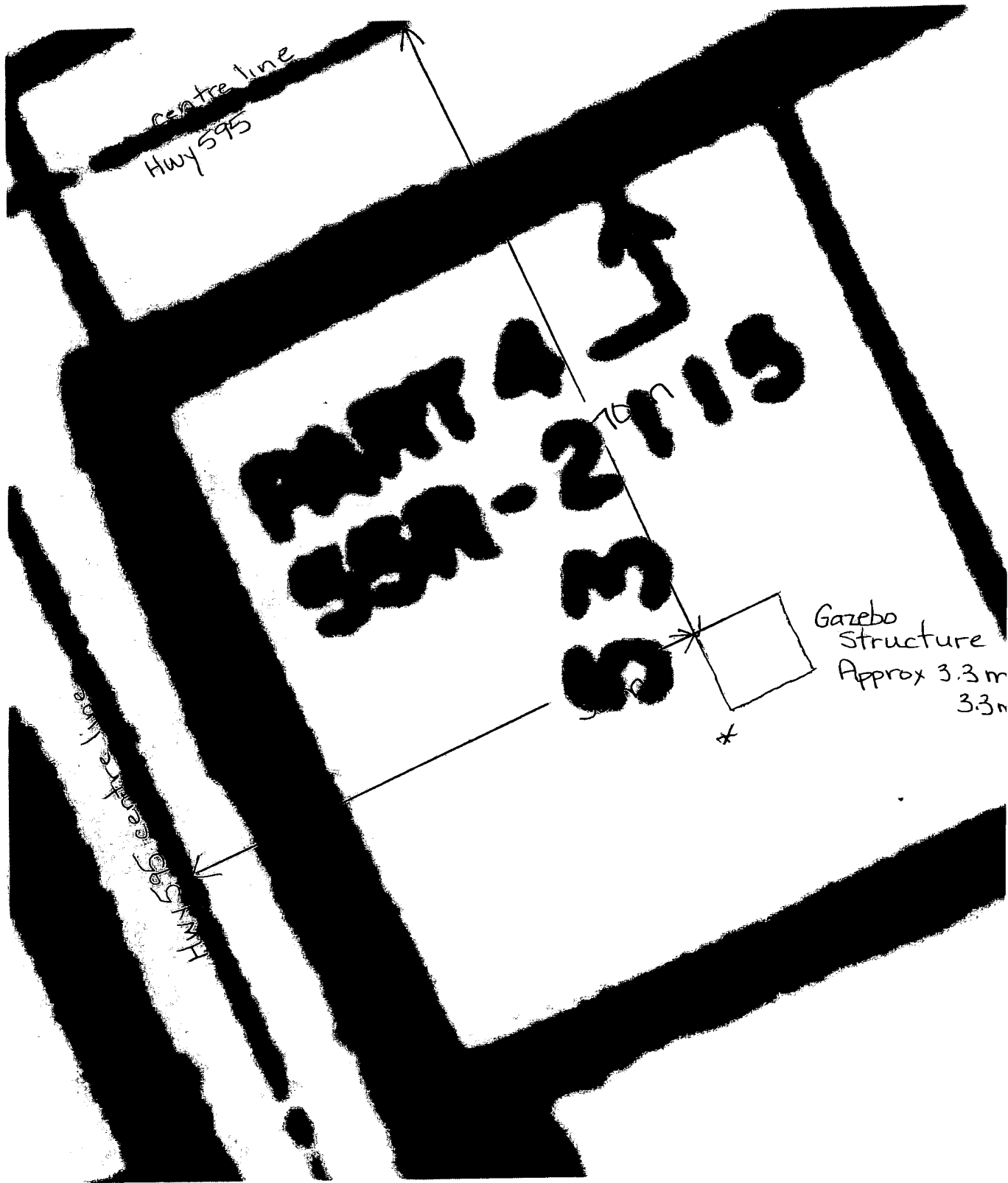

*exact location subject to approval of mto building permit. Location will be marked once approval received.

Township of Gillies

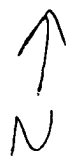

G.2 TOP VIEW

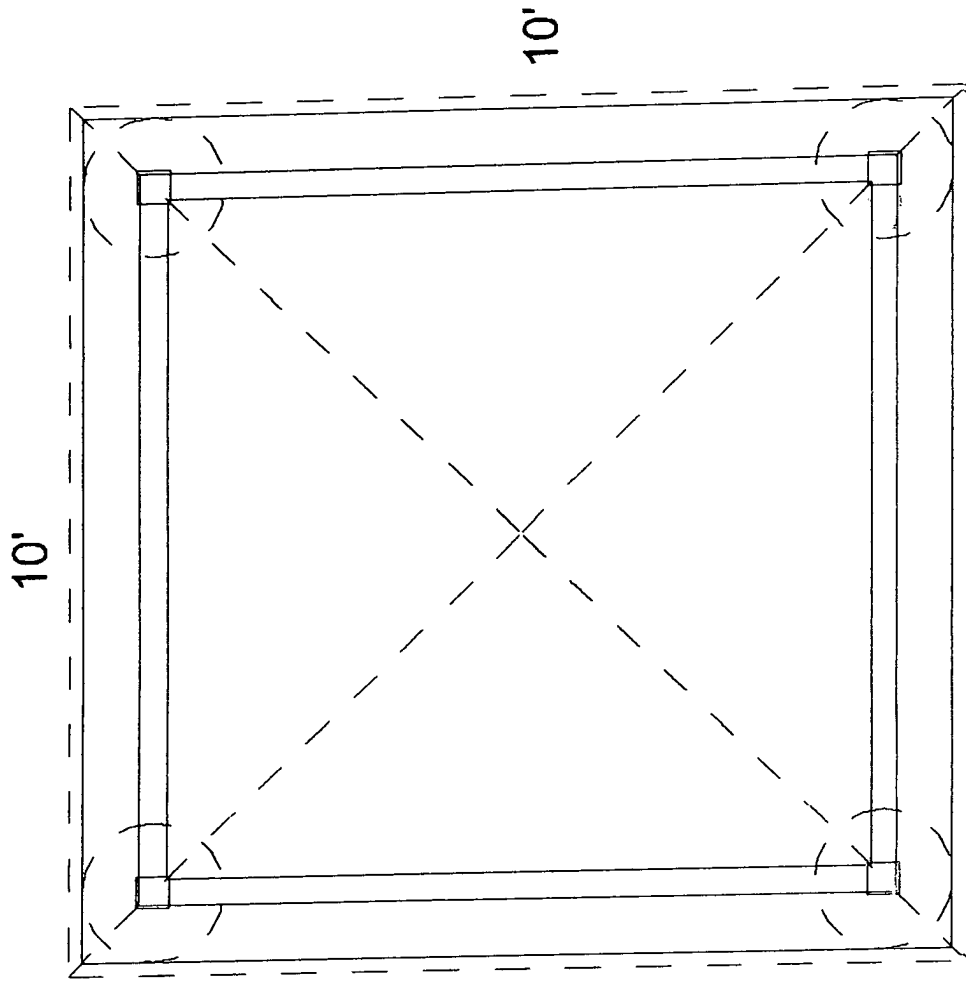

10'X10' STRUCTURE

12" OVER HANG HIP-STYLE ROOF

6X6 POSTS CAPPED IN WHITE METAL

POST IN CONCRETE/SONO-TUBE/BIG-FOOT

2X10 2 PLY BEAMS

G.3 Side View

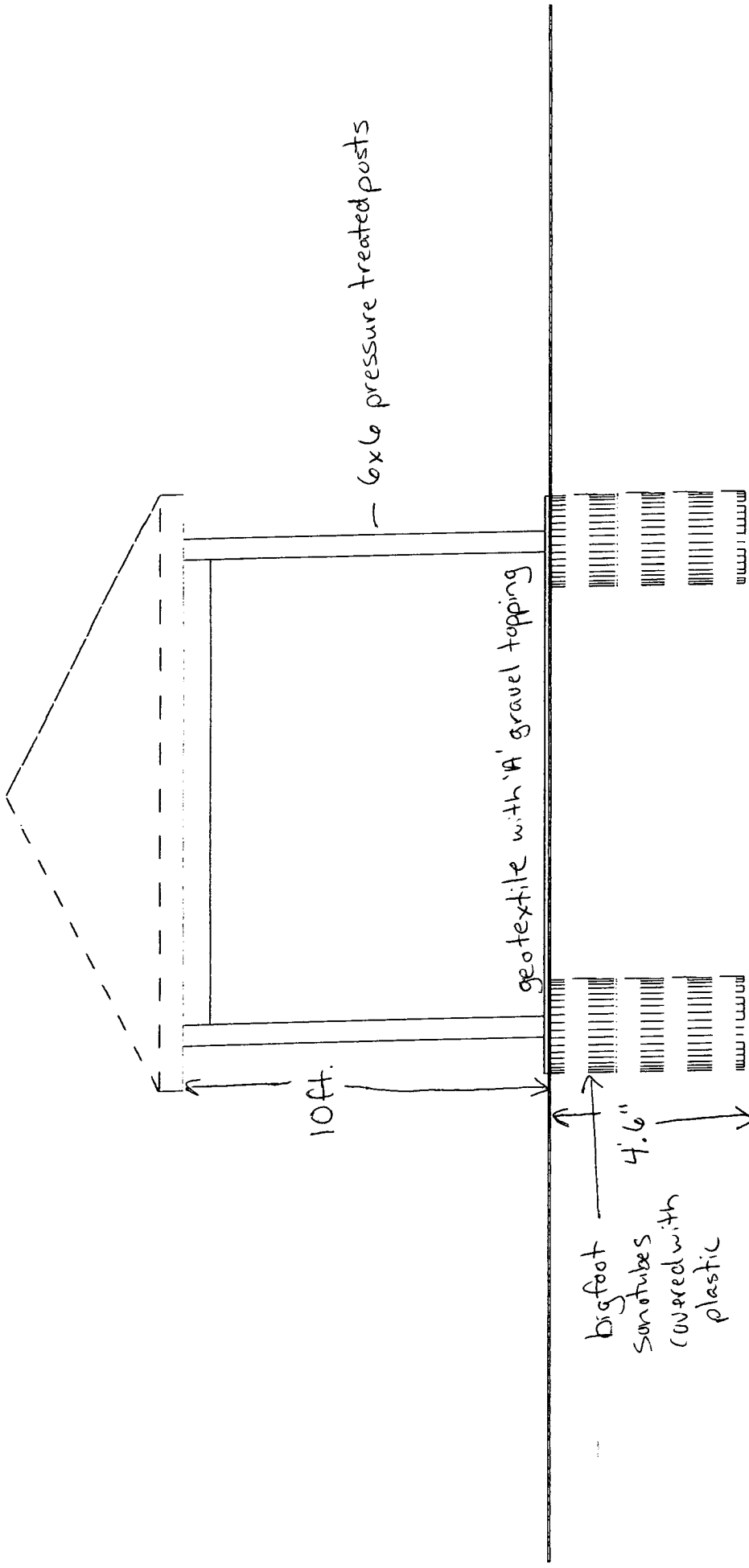

- white fascia (no soffit)
- dark green metal roof with matching snowstops
- posts capped in white metal